

**ROSS**  
**Embrace**<sup>™</sup>  
*Enteral Pump*

---

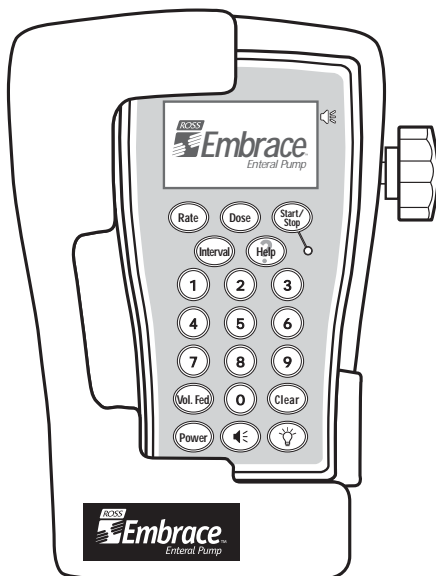

*Operating  
Manual*

---

*For Enteral Use Only  
Not for IV Use*

# CONTENTS

---

Pump Characteristics .....	4
Indications for Use .....	5
Precautions .....	5
Preparation for Use .....	5
Panel Displays .....	6
Pump Keys .....	6
Instructions for Use .....	9
Charging the Battery .....	13
Changing the Battery .....	13
Keypad Lockout .....	13
Checking Pump Accuracy .....	14
Troubleshooting .....	14
Cleaning .....	16
Storage .....	17
Service .....	17
Pump Sets .....	17
Optional Accessories .....	17
Specifications .....	18
Limited Warranty .....	19

## **USER QUALIFICATIONS**

The Ross Embrace™ Enteral Pump is for use at the direction of or under the supervision of licensed physicians and by licensed or certified health care professionals who are trained in the use of the pump and the administration of enteral fluids.

# Embrace™ Enteral Pump

## Illustrations

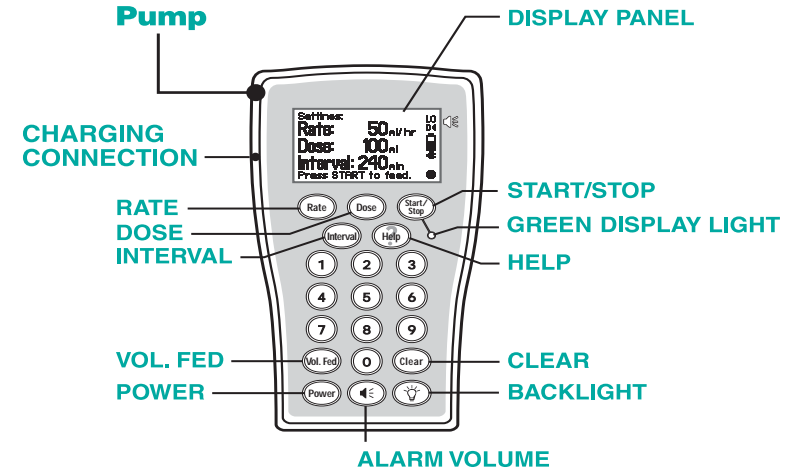

## Charger Base

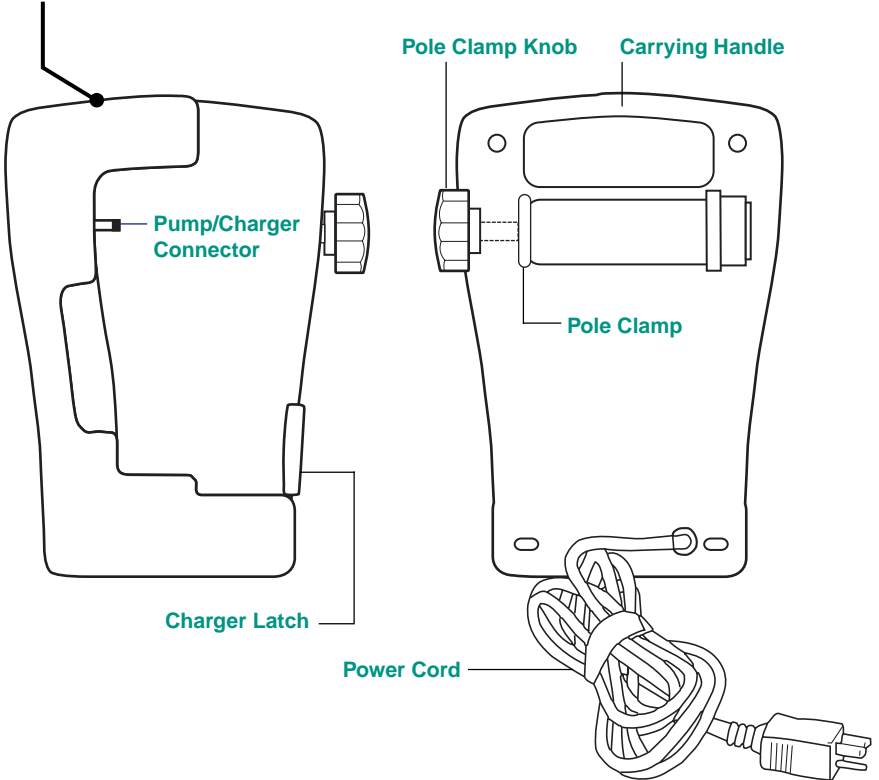

## PUMP CHARACTERISTICS

---

The Ross Embrace™ Enteral Pump is a microprocessor (computer)-controlled pump that provides for accurate, controlled enteral feeding delivery in a safe, user-friendly system. The Embrace Pump is a volumetric pump that uses a specially designed feeding set, which includes a cassette that delivers measured amounts of enteral product.

### **The Embrace Pump offers these features:**

#### **Safe**

- Anti-free flow system (protection against overdelivery)
- System self-check
- Keypad lockout
- Built-in help feature
- Safety review of settings screen
- Audible and visual alarms
- Long-lasting nickel metal hydride battery
- Backlight for nighttime use

#### **Simple**

- Easy-to-use numeric keypad for direct entry of values
- Cassette technology for simple one-hand set loading
- Automatic set priming
- Memory retention of keypad settings (if <24 hours since last use)
- Graphic display panel
- Volume fed accumulation

#### **Selectable**

- Programmable hold timer
- Interval feeding mode
- Flow rate
- Adjustable high/low audio volume
- Dose complete alarm
- Travel accessories

The Embrace Enteral Pump can be used in virtually any setting by pediatric and adult patients whenever accurate delivery of enteral nutrition liquids is required. Its small size and weight also make it a great choice for mobile tube-fed patients who take along their enteral pump. An array of optional travel accessories makes tube feeding less intrusive on active lifestyles.

## INDICATIONS FOR USE

---

The Embrace™ Enteral Pump can be used to provide enteral nutrition (tube feeding) for adult and pediatric patients as long as the patients can tolerate a feeding range within the pump operational specifications. Those specifications are:

- The flow rate range is 1 to 500 mL/hr in 1-mL increments.
- For rates from 1 to 500 mL/hr, the flow rate accuracy is  $\pm 5\%$  or  $\pm 0.5$  mL/hr, whichever is greater.\* (See page 14 for **Checking Pump Accuracy**.)
- Pumps against 20 psi nominal back pressure before FLOW BLOCKED alarm.

**If these specifications are not appropriate for a given patient, the Embrace Pump should not be used.**

\* Accuracy tested with Ensure® Powder (reconstituted), Ensure® Fiber With FOS, Glucerna®, and water.

## PRECAUTIONS

---

- All enteral pumps have the potential to bolus-feed or overdeliver, which is an important consideration in feeding volume-sensitive patients. In these patients, do not hang more volume of nutritional product than can be tolerated as a bolus.
- NOT FOR INTRAVENOUS (IV) USE.
- This pump is designed to deliver only a liquid enteral feeding product (standard liquid product, infant formula, or reconstituted powder product that has been thoroughly mixed into solution).

***DANGER: Possible explosion hazard if used in the presence of flammable anesthetics.***

**Check to make sure that the orange plunger on the Embrace pump cassette is pushed in completely.**

## PREPARATION FOR USE

---

To avoid complications, confirm proper placement and function of patient's enteral feeding tube (nasogastric, jejunostomy, gastrostomy, etc). Verify the following before initiating feeding:

1. **Only a new Embrace Enteral Pump Set is being used.** Pump set and container should be replaced as needed to avoid fluid contamination problems. Use according to pump set labeling. **For single-patient use only.**
2. Cassette is properly seated in pump and door is properly closed.
3. The pump must be upright for priming whether in the charger base, set on a table, or attached to a pole.
4. Flow rate (and dose if used) are set at the prescribed settings.
5. Interval feeding (if used) is at the prescribed settings for time, dose, and rate.
6. The CAIR® clamp is fully open before feeding.
7. Clear the volume fed value if setting rate and dose without use of the interval feature. (See page 7, **Clear**.)

## PANEL DISPLAYS

Here is a simple explanation of the panel displays. Understanding them is necessary for successful operation of the pump.

**NOTE: In some operational modes, some keys do not have a function. Pressing one of those keys will sound a single low-volume tone.**

## PUMP KEYS

### Power (On)

**Power** Pressing the **POWER** key turns the pump ON. After the pump is turned on, the pump immediately performs an internal system self-test, and if the pump set is loaded into the pump, it automatically primes the pump set. Before initiation of the priming cycle, the current rate and dose volumes are presented on the display. The battery energy level is always present on the display when the pump is turned on or the pump is connected to AC power, and is depicted by a battery-shaped icon. For more information on the battery icon, see the **Charging the Battery** section (page 13).

### Power (Off)

**Power** Pressing the **POWER** key while the pump is ON turns the pump OFF. The pump's memory will retain the current RATE, DOSE, INTERVAL, and VOLUME FED values as long as the pump is used at least every 24 hours. After 24 hours of nonuse, the values are reset to zero.

### Rate

Pressing the **RATE** key allows the user to set the desired flow rate (1 to 500 mL/hr in 1-mL increments) by using the number keys. To change the flow rate, enter a new value using the number keys. Rate may be set during or after the priming cycle.

### Dose



Pressing the **DOSE** key allows the user to set the desired dose volume (1 to 9999 mL in 1-mL increments) by using the number keys. To change a displayed dose, enter a new value using the number keys. When the volume fed amount equals the dose set, the pump will alarm DOSE COMPLETE (except in INTERVAL mode). Dose may be set during or after the priming cycle. Setting dose to zero (0) disables the dose feature.



**NOTE:** If a zero dose (0) is entered, the DOSE feature will be turned off. The pump will deliver all nutritional product in the bag and then alarm BAG EMPTY.

**NOTE:** DOSE has a different meaning if the pump is placed in the INTERVAL mode. See the **Interval** section (page 8) for more information.

### Start/Stop (Feeding Start)

 Pressing the **START/STOP** key displays current settings. Pressing the **START/STOP** key a second time begins feeding, and then the pump will display the rate and dose settings. If an interval feeding mode has been selected, the time before the next dose is also displayed. The GREEN DISPLAY LIGHT on the front of the pump will begin to flash, indicating that the pump is in the START mode and currently delivering nutritional product. The droplet icon  will also begin to scroll from top to bottom on the display.

### Start/Stop (Feeding Stop)

 Pressing the **START/STOP** key while in the feeding mode will stop the pump. The pump will alarm after 5 minutes of inactivity. The user may change the STOP mode time setting by entering a new value using the number keys.

**Valid time settings are from 5 to 120 minutes.**

**NOTE:** The **START/STOP** key is used to silence any alarm. The pump will alarm after 5 minutes of inactivity, unless the STOP mode time setting is changed.

### Vol. Fed

 Pressing the **VOL. FED** key will display the amount of nutritional product delivered since the volume fed was last reset to zero (0). This message will be displayed for 5 seconds before returning to the previous screen.

### Clear (Vol. Fed)

 Pressing the **CLEAR** key in the STOP mode while the volume fed is shown on the display will bring up a message indicating that pressing the **CLEAR** key again will reset the volume fed to zero (0). This message will be displayed for 5 seconds before returning to the previous screen. The volume fed amount can be reset to zero only when the pump is in the STOP mode.

### Clear (Rate, Dose, and Interval)

 The **CLEAR** key can also be used to clear an incorrect entry in RATE, DOSE, or INTERVAL modes. The displayed value will be set to zero.

## Interval

**Interval** Pressing the **INTERVAL** key instructs the pump to deliver the entered dose volume multiple times, at set intervals (1 to 360 minutes), until the entire nutritional product in the bag has been delivered. The interval time is the time between the start of one dose and the start of the next dose. Setting the interval time to zero (0) disables the interval feature. When the interval feature is used, DOSE refers to the volume of nutritional product to be delivered during each interval (instead of the total volume to be administered). For example: To deliver 100 mL of nutritional product at a rate of 50 mL/hr and repeat this feeding every 4 hours (240 minutes), follow the example below:

**Rate** With the pump ON: Press the RATE key; enter 50 mL/hr.



**Dose** Press the DOSE key; enter 100 mL.

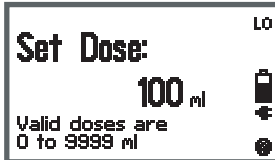

**Interval** Press the **INTERVAL** key. Using the number keys, enter 240 minutes.



**Start/Stop** Press **START/STOP** for safety review of settings. Press **START/STOP** a second time to begin delivery of nutritional product.

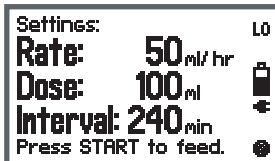

Hours-to-Minutes Conversion	
Hours	Minutes
1/2	30
1	60
1 1/2	90
2	120
2 1/2	150
3	180
3 1/2	210
4	240
4 1/2	270
5	300
5 1/2	330
6	360



## Help

**Help** Pressing the **HELP** key displays text and graphic messages to help the user in operating the pump and responding to alarm conditions. Help is available to the pump user in a number of situations. Help can be requested anytime the  icon is displayed in the lower right portion of the display. The HELP screens are intended to be used in addition to the information provided in this operating manual. If the HELP key is pressed while programming the pump or responding to an alarm, the pump will display information on the

screen that corresponds to the current mode or situation. This menu offers the user help on several pump topics. To view information on a specific topic, press the number key corresponding to the subject to be reviewed. Follow the instructions on the screen to use the HELP screens. The user may exit the HELP menus anytime by following the instruction on the display or by pressing START/STOP.

## Alarm Volume



Pressing the  (ALARM VOLUME) key once displays the current audio volume level—AUDIO VOLUME HIGH or AUDIO VOLUME LOW—and sounds a double tone. It also shows the status of the DOSE COMPLETE ALARM (ON or OFF). A display message will read “Press 1 to change Audio Volume. Press 3 to change Dose Complete Alarm.” The audio volume level is indicated in the settings by the words HI and LO next to the picture of the speaker at the right of the display. When the DOSE COMPLETE audio alarm is turned off, the icon  is displayed in the SETTINGS screen.

## Backlight



When plugged into AC power, the  (BACKLIGHT) key turns the backlight on or off. Pressing the BACKLIGHT key while running on battery power lights the display for 60 seconds.

## INSTRUCTIONS FOR USE

Before initial use on battery power and after extended storage periods, the pump must be plugged into an AC power source (standard wall outlet) for at least 6 hours (pump may be operated during this time). Use AC power whenever possible. Periodically plug the pump into AC power during storage to assure a fully charged battery for emergencies.

### USE WITH CHARGER BASE:

Hold the charger base latch while sliding the pump into the base. The pump is fully seated into the charger base when the charger latch is released.

### OPERATION:

1. Complete self-adhesive delivery label and affix to feeding container.
2. Check to make sure that the orange plunger on the Embrace pump cassette is pushed in completely.
3. Fill feeding container with enteral nutritional product or use a prefilled enteral feeding container. Attach the Embrace pump set securely onto a filled container if it is not preattached. Suspend container to the side or behind and 20 inches above pump. Squeeze sight chamber  $\frac{1}{3}$  to  $\frac{1}{2}$  full. (The 500-mL ambulatory bag does not have a sight chamber.)

4. Open the pump cassette door by pushing the door latch up, releasing the door (A). Slide the cassette into the door, making sure that the cassette is fully inserted (B). With the cassette fully seated into the door, press the top of the door into the pump (C). When the cassette door is properly in place, the door latch will drop down and engage the door, holding it securely in place. When properly seated, the latch will not protrude above the top of the pump. **The pump will not operate properly when the door latch is not properly engaged.**

(A) Push up on latch to release door

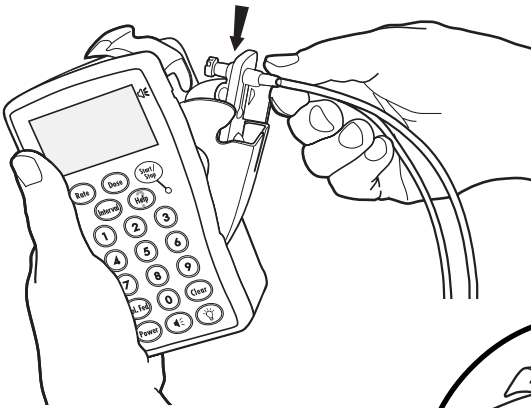
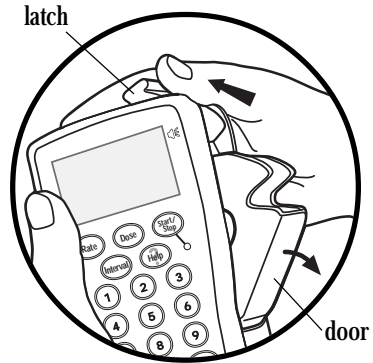

(B) Slide cassette into door

(C) Press top of door to close



TO PRIME:

**Pump automatically primes.**

1. Remove set adapter cover.
2. The pump must be upright for priming whether in the charger base, set on a table, or attached to a pole.
3. Press the POWER key on the front of the pump. The pump will initiate a system self-check procedure, followed by automatic priming of the set.

Additional pump settings may be entered at this time. However, delivery of nutritional product cannot be started until priming has been completed.

**NOTE:** Automatic priming expels air from the set, and may result in a small amount of fluid being expelled beyond the adapter. Do not connect the feeding set to the patient's feeding tube until the feeding set has been completely primed.

**To gravity feed or manually prime:**

1. Completely close CAIR® clamp.
2. Remove cassette from pump.
3. Pull out orange plunger on cassette and regulate flow with CAIR clamp.

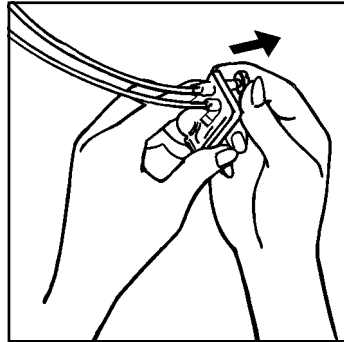

TO RUN:

1. **Confirm proper placement and function of enteral feeding tube.**
2. Attach feeding set adapter to enteral feeding tube.
3. Select a flow rate from 1 to 500 mL/hr by pressing the RATE key and entering the desired rate using the number keys.
4. Clear the volume fed value, if necessary.
5. If a dose is desired, press the DOSE key and enter the desired dose using the number keys.  
**Note:** If a zero dose (0) is entered, this feature is deactivated.
6. Select an interval, if desired. (See page 8, **Interval**.)
7. Press the START/STOP key to review the settings.
8. Press the START/STOP key again to start feeding.

**Note:** After the system self-check and priming are complete, the SETTINGS screen is presented on the pump display. The SETTINGS screen displays the set values for rate and dose (and interval time, if used). If these values are correct, there is no need to reenter the values; press START/STOP again to start feeding. The rate and dose to be delivered are presented on the display.

When the START/STOP button is pressed after new pump settings are entered, the SETTINGS screen will always be presented. The operator should review the information on the SETTINGS screen and must press START/STOP once more to begin delivering the nutritional product.

#### BATTERY OPERATION:

The pump will operate for at least 18 hours, at 125 mL per hour, on a fully charged battery. The battery icon  on the display indicates the battery energy level. The battery icon will be displayed in the priming mode, START mode, and STOP mode. The relative amount of battery energy remaining is indicated by the amount of solid area within the battery icon. When the battery is fully charged, the inside of the battery icon is solid. As the battery energy decreases, the battery icon becomes increasingly hollow or empty.

When 30 minutes of battery life are remaining, an alarm will sound and the battery icon  will flash repeatedly. Pressing the START/STOP key once will silence the alarm and place the pump into the STOP mode. Pressing the START/STOP key a second time will place the pump into the START mode; the battery icon will continue to flash, but the audible alarm will be silenced.

When the battery energy level is too low to properly operate the pump, the alarm will sound with a long tone, followed by the pump automatically turning off.

## CHARGING THE BATTERY

---

To charge the battery, place the pump into its charger base or insert the optional AC adapter/charger barrel connector into the matching receptacle on the side of the pump. Insert the charger base plug or optional AC adapter/charger in an appropriate AC outlet, as listed in the **Specifications** section (page 18). Whenever the pump is connected to AC power, the AC icon  will be displayed.

The battery will be fully charged in 6 hours or less, even when the pump is delivering nutritional product, and is indicated when the battery icon  is completely solid.

**NOTE:** Use **only** the Embrace™ charger base or optional Embrace AC adapter/charger to charge battery.

## CHANGING THE BATTERY

---

1. Disconnect pump from AC power supply.
2. Use Phillips screwdriver to remove screw on battery compartment door. Remove door.
3. Unplug Embrace battery pack.
4. Plug in new Embrace battery pack.
5. Replace door and screw in securely.

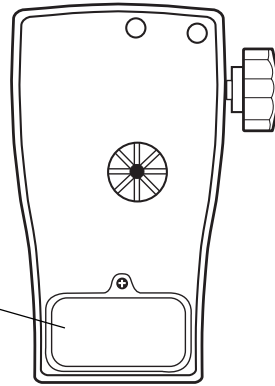



Battery Compartment Door

## KEYPAD LOCKOUT

---

Enabling the keypad lockout prevents unauthorized or accidental changes to the pump settings. The keypad lockout disables all keys except BACKLIGHT, those keys needed to unlock keypad, and VOL. FED.

- To enable the keypad lockout, the pump must be in the START mode (pump is running; green display light is blinking).
- While in the START mode, simultaneously press the **1** and **3** keys and hold for 4 seconds. The lockout icon  will be displayed.
- To turn the keypad lock off, simultaneously press the **1** and **3** keys and hold for 4 seconds again. The lockout icon  is no longer displayed and the keypad is fully functional.
- During any alarm, the keypad is automatically unlocked and must be relocked by the pump user after the alarm has been corrected and the pump is in the START mode.

## CHECKING PUMP ACCURACY

---

To check flow rate accuracy, use the following procedure:

**Select a new pump set for this test.** Be sure to use a graduated cylinder for volume measurement—not an enteral container or other uncalibrated container. Fill the feeding container using water and set up pump according to instructions. Suspend container to side or behind and 20 inches above pump (see illustration).

With the Embrace™ Enteral Pump connected to AC (standard) power, start the pump and let it run for 15 minutes. Then run fluid into a graduated cylinder for 30 minutes and compare to rate set on pump.

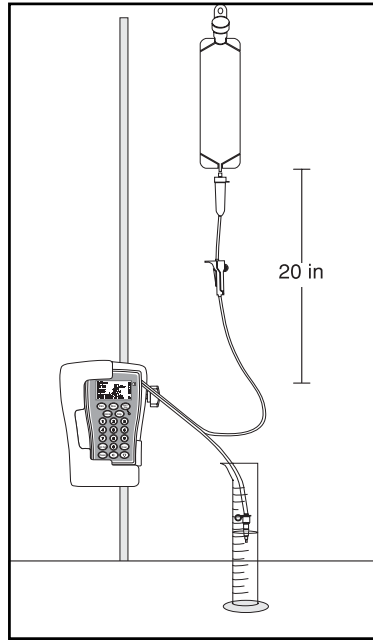

**NOTE:** Amount delivered in 30 minutes will be half of the value set for the hourly flow rate  $\pm 5\%$ .

<u>Rate Set</u>	<u>Amount Expected in Graduated Cylinder @ 30 minutes</u>
76 mL/hr	= 36.1 mL to 39.9 mL
150 mL/hr	= 71.2 mL to 78.8 mL

If amount in graduated cylinder is incorrect based on the set rate, try a new pump set and repeat test procedure.

## TROUBLESHOOTING

---

The Embrace Enteral Pump is designed to be highly reliable. As with any electro-mechanical device, however, problems may occur. Intermittent audio alarms are accompanied by messages on the visual display indicating the cause of the alarm for all alarm conditions. The following tips will help correct problems that may arise:

Alarm Display	Condition or Problem	Corrective Action
BAG EMPTY	The cassette is not filling with nutritional product properly—most likely because the bag is empty, but there may be other causes	<ul style="list-style-type: none"> <li>• Press START/STOP to silence alarm</li> <li>• Check to see if bag is empty; refill if more nutritional product is needed</li> <li>• Check to see if the line between the bag and the cassette is blocked or clamped shut. Correct the problem</li> <li>• Excessive air may be trapped in the cassette. Set pump upright, turn pump off, disconnect feeding set from tube, and turn the pump back on to start automatic priming. After priming, reconnect feeding set to feeding tube</li> <li>• Press START/STOP to restart feeding</li> </ul> <p><b>NOTE:</b> This alarm may occur if thick nutritional products are pumped at high flow rates</p>
FLOW BLOCKED	The flow of nutritional product from the pump to the patient has been blocked	<ul style="list-style-type: none"> <li>• Press START/STOP to silence alarm</li> <li>• Verify that the CAIR® clamp is open</li> <li>• Make sure that the set from the pump to the feeding tube is patent</li> <li>• Press START/STOP to restart feeding</li> <li>• If alarm continues, feeding tube is likely blocked; consult a medical professional</li> </ul>
PRIMING ERROR	The pump is not able to prime set	<ul style="list-style-type: none"> <li>• Press START/STOP to silence alarm</li> <li>• Verify that the CAIR clamp is open</li> <li>• Make sure that tubing is not kinked</li> <li>• Press START/STOP to restart feeding</li> <li>• If alarm continues, discard the set and try another set. If the alarm occurs again, the pump likely requires servicing</li> </ul>
CASSETTE OUT	There is no cassette properly installed in the pump	<ul style="list-style-type: none"> <li>• Properly install a cassette</li> </ul>
DOSE COMPLETE	The volume fed is equal to the value set for DOSE	<ul style="list-style-type: none"> <li>• Press START/STOP to silence alarm</li> <li>• Enter new DOSE value to increase the dose, or set DOSE to zero (0), or clear VOL. FED value</li> <li>• Press START/STOP to restart feeding</li> </ul>
INVALID _____	Invalid RATE, DOSE, or INTERVAL TIME has been entered	<ul style="list-style-type: none"> <li>• Pump will clear this alarm and value automatically and allow the operator to enter a valid RATE, DOSE, or INTERVAL TIME</li> </ul>
LOW BATTERY	The battery has only 30 minutes before it is unable to operate the pump	<ul style="list-style-type: none"> <li>• Place the pump in its charger base or use the Embrace™ AC adapter/charger to connect it to a standard wall outlet</li> </ul>
DISCHARGED BATTERY	The battery does not have sufficient energy remaining to properly operate the pump	<ul style="list-style-type: none"> <li>• Place the pump in its charger base or use the Embrace AC adapter/charger to connect it to a standard wall outlet</li> </ul>
WAITING FOR INPUT	The pump is awaiting user input	<ul style="list-style-type: none"> <li>• Press START/STOP to silence alarm and restart timer</li> <li>• Complete the entry</li> <li>• Reset STOP mode time setting, if desired</li> </ul>
INTERNAL ERROR	Pump requires further evaluation	<ul style="list-style-type: none"> <li>• Contact Ross Device Call Center</li> </ul>

## CLEANING

For trouble-free operation, clean immediately after spills occur.

**Turn pump off and unplug charger before cleaning. Do not submerge, autoclave, heat, steam, ETO, or radiation sterilize the pump or charger.**

The pump and charger can be cleaned as follows:

### HOUSING

- Clean outside surface only (do not spray water or cleaning solution into pump).
- For general cleaning use soft cloth and warm soapy water. Rinse and dry thoroughly.
- For general disinfecting or disinfecting after exposure to tuberculosis, use 70% concentration isopropyl alcohol.
- For disinfecting after exposure to AIDS or hepatitis, use 10% concentration of 5.25% sodium hypochlorite (household bleach). This solution may discolor the pole clamp.

**NOTE:** These recommendations are not substitutes for official procedures that may differ among institutions.

### PUMP CAVITY

To facilitate cleaning, the cassette door and latch may be removed from the pump:

- Lift the latch into its highest position and hold it there.
- Grasp the sides of the door (near the top) and gently squeeze them to free the door from the pump body.
- Swing the top of the door out and remove door from pump.
- While holding the latch, allow it to move downward until the spring tension is released.
- Slide the latch out of the pump body.

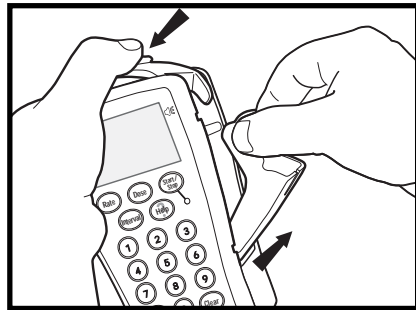

To reinstall the door and latch:

- Align the latch pivot pins with the slot in the pump body and slide the latch into the pump until the latch can be pivoted up.
- Lift the latch into its highest position and hold it there.
- Slide the door pivot pins into the slot near the bottom of the pump cavity.



- Swing the door until the door sides meet the pump body. Gently grasp the sides of the door and squeeze them inward while swinging the top of the door into the pump.
- While holding the latch, allow it to move downward until the latch and door are in their closed positions.

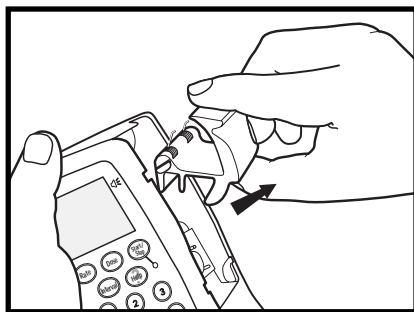

## STORAGE

---

- The pump should be stored away from excessive heat, cold, or humidity.
- Be sure pump is in the **POWER (OFF)** position.
- Connect the pump periodically to AC power during storage to assure a fully charged battery for emergencies.

## SERVICE

---

There are no routine calibration or adjustment procedures required with the Embrace™ Enteral Pump. All servicing or adjustments should be referred to qualified technical Ross personnel.

**CAUTION: Electrical shock hazard. Do not open charger case.**

In the event of a pump malfunction or for technical assistance or parts, please contact your pump provider or the Ross Device Call Center.

**WARNING: Disconnect AC power cord before servicing.**

## PUMP SETS

---

Pump feeding sets available for use with the Embrace Enteral Pump:

- #55355 500-mL Ambulatory Bag
- #55359 Pump Set with Piercing Pin
- #55361 Embrace Screw Cap Set
- #55747 1000-mL Top-Fill Enteral Nutrition Bag

## OPTIONAL ACCESSORIES (May be purchased separately)

---

- #55352 Embrace AC adapter/charger
- #55749 Embrace carrier (holds pump and 500-mL bag)
- #56739 Removable pole clamp

## SPECIFICATIONS

---

### ELECTRICAL

Input Voltage:	100 to 130 VAC, 60 Hz, 1-Phase
Input Power:	48 watts maximum
Fuse:	400 mA, time-delay type
Line Cord:	Hospital-grade, nondetachable (10 feet)
Leakage:	Less than 100 microamps
Protection:	Class 1
Applied Part Isolation:	Type BF

### MECHANICAL

	Charger Base	Pump
Height (inches)	7	6.1
Width (inches)	5	3.4
Depth (inches)	8	2.3
Weight (lbs)	2.5	1.5

### ENVIRONMENTAL

Operating Temperature:	40°F–104°F
Storage Temperature:	-29°F–140°F

### OPERATIONAL SPECIFICATIONS—FLOW RATES

Range:	1 to 500 mL/hr
Increments:	1 mL/hr
Accuracy:	± 5% or ± 0.5 mL/hr (whichever is greater) for rates from 1 to 500 mL/hr. (Refer to <b>Checking Pump Accuracy</b> , page 14.) <small>(Accuracy tested with Ensure® Powder (reconstituted), Ensure® Fiber With FOS, Glucerna®, and water.)</small>
Pressure:	Pumps against nominal 20 psi back pressure before FLOW BLOCKED alarm.
Memory:	Retains settings for rate, dose, interval, and volume fed for 24 hours of nonuse (even turned off and unplugged).

### BATTERY OPERATION

Type:	Rechargeable Ni-MH
Voltage:	4.8 V nominal
Expected Life:	18 hours at 125 mL/hr after fully charged
Recharge Time:	6 hours maximum, regardless of pump operation

### STANDARDS

Designed and manufactured to meet UL 2601-1 and CSA C22.2 No. 601.1

### EXPLANATION OF SYMBOLS



Applied Parts Type BF Equipment



Attention, consult ACCOMPANYING DOCUMENTS

**IPX4** Protected against splashing water

## LIMITED WARRANTY

---

Ross Products Division of Abbott Laboratories warrants the Ross Embrace™ Enteral Pump against defects in material and workmanship for a three (3) year period from date of delivery. This warranty is valid only to the original purchaser and does not extend to any product, or part thereof, which has been subjected to accident, alteration, damage, misuse, repair by other than Ross authorized representatives, or has not been operated and maintained in the manner prescribed in the Operating Manual or which at the time of pump failure was being used with pump sets or containers other than Ross pump sets and containers. Examples of damage or misuse include, but are not limited to, pumps that have been dropped, have had fluid spilled into or onto the casing or have been submerged.

In no event shall Ross be liable for any incidental, indirect or consequential damages in conjunction with the purchase or use of the pump, even if advised of the possibility of the same.

Ross reserves the right to repair or replace (at its option) any pump that fails to meet the foregoing warranty.

**THE WARRANTIES HEREUNDER ARE IN LIEU OF ALL OTHER WARRANTIES, EXPRESSED OR IMPLIED, INCLUDING, WITHOUT LIMITATION, THE WARRANTIES OF MERCHANTABILITY AND OF FITNESS FOR A PARTICULAR PURPOSE.**

**NOTE:** When repairs on the unit are made under warranty because of faulty material or workmanship within three (3) years from the date of delivery to the customer, the customer will not be billed for parts repaired or replaced. Also, the customer will not be charged for labor involved in connection with the installation of such parts furnished under warranty.

Shipping costs for units returned to Ross, including loaners, shall be paid by the customer. The units should be promptly returned properly packaged. Loss or damage in return shipment to Ross shall be at the customer's risk. Ross authorization should be obtained to return the unit.



**ROSS** ROSS PRODUCTS DIVISION  
ABBOTT LABORATORIES INC.  
COLUMBUS, OHIO 43215-1724 USA